

User manual

DRY AGER® DX500 Premium S

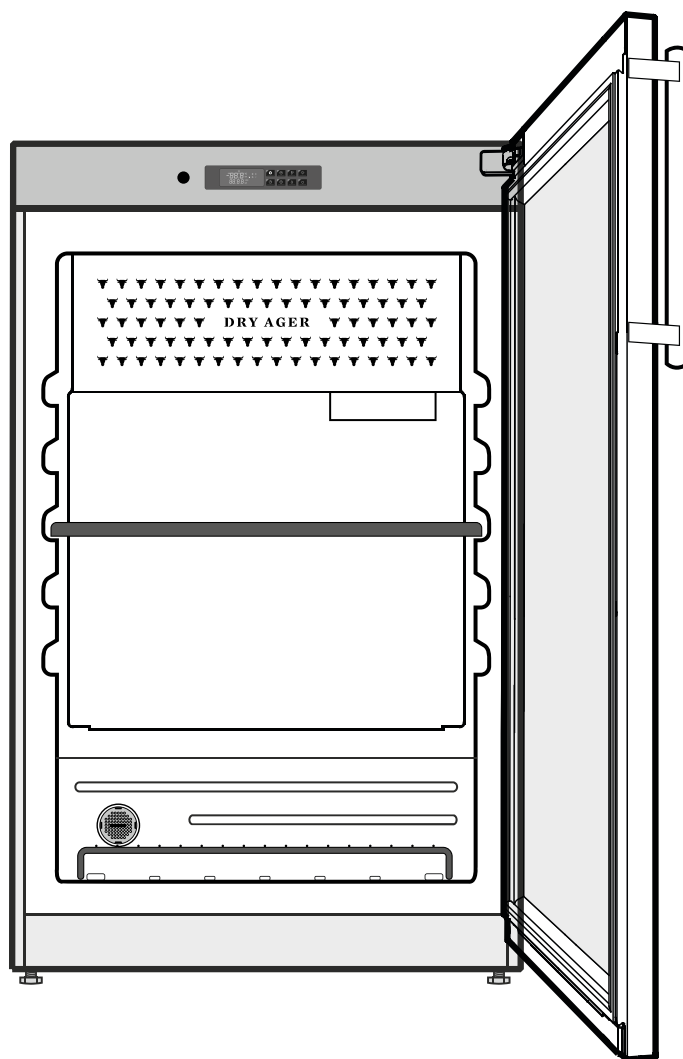

**Professional Dry Aging at home and for business,
with the new DRY AGER® Premium S series.**

Table of contents	Page
Dry Aging	2
Safety and warning instructions	3
Climate class	4
Energy saving	4
Power connection	4
Noise emission	4
Disposal information	4
Area of application of the unit	4
Quick starter tips	5
Unit description	6
Integrated systems	6
Dimensions	7
Installation drawings	7
Setting up the unit	8
Preparing the unit	8
Loading the unit with food	8
Food selection	8
Loading the unit	8
Considering maturing time	9
During operation	9
Switching off the unit	9
Operating and control elements	10
Overview of controllers	10
Control buttons	10
Control buttons combinations	10
Symbols and characters	10
Starting operation	11
Power supply	11
Turning on the unit	11
Switching the interior lighting on/off	11
Switching on the UVC sterilization	11
Standard mode	11
Activate standard mode	11
Selection Dry Aging or ham and sausage production	11
Setting the temperature	12
Setting the humidity	12
SmartAging® mode	12
SmartAging® Select program	12
Start SmartAging®	12
Finish SmartAging®	12
Locking and unlocking the keypad	12
Locking and unlocking the doors	12
Cleaning	13
Preparation	13
Cleaning the accessories	13
Cleaning the interior	13
Starting the cleaning program	13
Cleaning the outside	13
Troubleshooting	13
Alarm messages	14
Maintenance	14
Customer service	14
Information about the unit	14
Disclaimer	14
SmartAging® program selection	15
Program guide	16
Changing the door hinge	20

Dry Aging

Good things come to those who wait, especially when it comes to food that is dry aged.

Dry Aging is one of the oldest known preparation techniques that requires time, patience, and attention to detail. It is a process that must not be rushed. The reward is unexpected nuances of flavor and changes in texture that make the meat, fish, or ham unique. Steaks as tender as butter. Fish, infinitely intense with an incomparable bite. Homemade hams and sausages with a phenomenal taste. In short, food at its highest level of refinement

How does Dry Aging work?

During Dry Aging in the DRY AGER® cabinet, the meat, fish, ham, sausage, or cheese age for a certain period of time at controlled temperature, humidity, air movement, and air quality. Instead of lying airtight in plastic wrap, the food is allowed to mature in peace and do what it loves to do: breathe.

The DRY AGER® Dry Aging cabinet combines time-honored methods with state-of-the-art technology to make Dry Aging easier, safer, and more consistent than ever before. Thanks to SmartAging®, not only beef, but also ham, salami, sausage products, fish, cheese and more can now be aged - all at the touch of a button!

Sophisticated Dry Aging technology is the key

The DRY AGER® Premium S models have such a large range of parameters that, in combination with sophisticated technology, the aging of a wide variety of foods is possible. Various legally protected innovations ensure precise temperature control in the range between 0 °C and +30 °C. Humidity also plays an important role and, thanks to HumiControl®, it is electronically controlled in the range from 40% to 90%. Incidentally, without the need for a water connection or water tank – a 230 V power connection is sufficient.

Together with the integrated DX AirReg® system, a microclimate perfectly matched to the product is achieved, even with major fluctuations in ambient temperature.

Innovations Made in Germany!

We wish you a lot of pleasure and enjoyment with Dry Aging

Christian, Aaron, Andreas and Manfred Landig



At DRY AGER®, questions are competently answered by butchers, meat sommeliers and BBQ professionals who know what they are talking about.

Manufacturer direct contact:
+49 7581 9043-0 | info@dry-ager.com

Safety and warning instructions

- To avoid personal injury and material damage, the unit should be unpacked and set up by two persons.
- In the event of damage to the unit, contact the supplier immediately before connecting it.
- To ensure safe operation, only install and connect the unit in accordance with the operating instructions.
- In the event of a fault, disconnect the unit from the power supply. Pull out the power supply plug or remove or unscrew the fuse.
- Do not pull on the connecting cable, but on the plug to disconnect the unit from the power supply.
- Repairs and interventions on the unit may only be carried out by the Customer service, otherwise considerable dangers may arise for the user. The same applies to changing the power supply cable.
- Do not handle open flames or ignition sources inside the unit. When transporting and cleaning the unit, take care not to damage the refrigeration circuit. In the event of damage, keep sources of ignition away and ventilate the room well.
- Do not use pedestals, drawers, doors, etc. as steps or for support.
- This unit can be used by children aged from 8 years and above and persons with reduced physical, sensory or mental capabilities or lack of experience and knowledge if they have been given supervision or instruction concerning use of the appliance in a safe way and understand the hazards involved. Children are not allowed to play with the unit. Cleaning and user maintenance must not be carried out by children without supervision.
- Avoid prolonged skin contact with cold surfaces or chilled/frozen goods. This can lead to pain, numbness, and frostbite. In the event of prolonged skin contact, take protective measures, e.g. use gloves.
- Do not consume foods that have expired, this can lead to food poisoning.
- Explosive substances or spray cans with flammable propellants, such as propane, butane, pentane, etc. must not be stored in the unit. Any escaping gases could potentially be ignited by electrical components. Such spray cans can be identified by the printed contents or a flame symbol.
- Do not store keys for lockable units near the unit or within reach of children.
- The unit is designed for indoor use. Do not operate the unit outdoors or in damp areas or close to splashing water.
- The LED light strip in the unit is used to illuminate the interior of the unit. It is not suitable for room lighting.
- When transporting or operating the unit higher than 1500 m above sea level, the glass pane of the door may break due to the reduced air pressure. The fragments are sharp-edged and can cause serious injuries.
- Repairs and interventions on the device should only be carried out when the power plug is visibly disconnected.



Do not use any mechanical aids or other means to accelerate the defrosting process other than those recommended by the manufacturer.



The power cable must not be damaged when setting up the unit.



This unit contains a UVC bulb. Never look directly into the light source.



Do not use electrical devices inside the unit.



Multiple sockets/distribution strips and other electrical devices (e.g. halogen transformers) must not be placed and operated at the rear of units.



Do not close the ventilation openings in the unit housing or in the installation housing.



Do not damage the refrigerant circuit.



Risk of injury from electric shock! Live parts are located under the cover. LED interior lighting may only be replaced or repaired by the customer service or by qualified personnel trained for this purpose.



Risk of injury from the LED lamp. If the cover is defective: do not look directly into the lighting with optical lenses from close range. This can result in damage of the eyes.



This symbol is shown on the compressor and indicates the danger of flammable hazardous substances.

Climate class

The climate class indicates the ambient temperature at which the unit may be operated in order to achieve full cooling capacity.

- The climate class is printed on the type plate.
- The position of the type plate can be seen in the chapter **Unit description** (page 6).

Climate class	max. ambient temperature	max. rel. humidity
7	35 °C	75 %

The minimum permissible ambient temperature at the installation site is 10 °C.

Do not use the unit outside the specified ambient temperatures!

Energy saving

- Always ensure good ventilation. Do not cover ventilation openings or ventilation grilles.
- Always keep fan ventilation slits clear.
- Do not set up the unit in an area of direct sunlight, next to a stove, heater or similar.
- The energy consumption depends on the installation conditions such as the ambient temperature.
- Open the unit for as short as time as possible.

Dust deposits increase energy consumption: Clean away dust from the chiller with the heat exchanger (metal grille at the back of the unit) once a year.

Power connection

The unit is **only** to be operated using **AC power** only.

- The permissible voltage and frequency are printed on the type plate. The position of the type plate can be seen in the chapter **Unit description** (page 6).
- The socket must be properly grounded and electrically fused.
- The tripping current of the fuse must be between 10 A and 16 A.
- The socket must not be behind the unit and must be easily accessible.
- Do not connect the unit using extension cords or distribution sockets.
- Do not use stand-alone inverters (converting direct current into alternating or three-phase current) or energy-saving plugs. Risk of damage to the electronics!

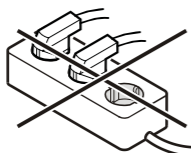

Noise emission

The noise level during operation of the unit is below 70 dB(A) (sound power rel. to 1 pW).

Disposal information

The unit contains valuable materials and must be disposed of separately from unsorted municipal waste. Disposal of disused units must be carried out professionally and appropriately in accordance with the locally applicable regulations and laws.



Do not damage the refrigeration circuit of the disused unit when removing it, to ensure that the refrigerant contained (information on the type plate) and the oil cannot escape in an uncontrolled manner.

- Pull out the power plug
- Cut through the connection cable
- Make the unit unusable



WARNING

Danger of suffocation from packaging material and foils! Do not let children play with packaging material. Take the packaging material to an official collection point.

Area of application of the unit

The unit is only suitable for cooling/conditioning meat or food in domestic or household-like environments and businesses.

All other types of application are not permitted. The unit is not suitable for the storage and cooling of medications, blood plasma, laboratory preparations or similar substances and products that are subject to the Medical Device Directive 2007/47/EC. Improper use of the unit can lead to damage to the stored goods or their spoilage. Furthermore, the unit is not suitable for operation in potentially explosive areas, outdoors or in areas with moisture and splashing water.

The unit complies with the relevant safety regulations as well as the EU directives 2006/42/EC, 2014/30/EU, 2011/65/EU.

Quick starter tips

These quick starter tips do not replace the detailed operating, warning and hazard information in the other chapters of the instructions for use.

General Information

1. Clean the interior of the unit. It is best to clean with DRY AGER® Special Cleaner, *item no. Z33145*. After each completed aging process, also activate the pre-cleaning program (P16) in addition to the spray cleaner. Duration: 2 hours.

2. When ordered: Unpack the salt blocks (remove the foil) and place the blocks in the stainless steel tray. Center the tray on the floor. If liquid is produced, empty the tray. Ideally, check every 2 - 3 days.

3. Plug the unit into a 220-240 V outlet and do not use a multiple outlet.

4. The DRY AGER® Premium S series cabinet can be operated in two different modes:

Standard mode

The display shows the values for temperature and humidity. These can be set in the range between 0 - / +30 °C and 40 to 90 % rH. The factory setting at start-up is 1.5 °C and 82 % humidity. This setting is ideal for dry aging beef or pork. Further details on using the **Standard mode** can be found from page 11.

SmartAging® mode

The SmartAging® program ("PG" + program number) and the temperature are shown in the display. Well-thought-out aging programs developed by professionals let you age to perfection. The appropriate program number is selected (see **SmartAging® program selection**, page 15), set in the controller and you are ready to go. Details on the use of the **SmartAging® mode** can be found from page 12.

5. Always wear protective gloves when coming into contact with the product. Likewise when buying, pay attention to how the seller treats the goods.

6. The activated carbon filter and the UVC lamp must be replaced annually for the unit to function properly. A maintenance message appears on the display before the end of the service life (see **Maintenance**, page 14).

Tips for meat

Meat is by far the most common dry-aged product, so here are a few special tips:

1. Meat for dry aging must be fresh, ideally max. 5 days after slaughter. Meat from vacuum bags can also be aged; the appropriate aging program can be found from page 16 onwards.

Tip for Dry Aged Beef: Use half saddles from a heifer and look for good marbling and fat cover.

2. Hang half saddles of beef on the hook in the DRY AGER® cabinet or place cuts on the optional shelves.

3. Loading capacity with hangers: A maximum of 2 x half saddles with a length of 0.5 m each fit into the unit, 2 hangers are required for this purpose.

4. Loading capacity with shelves (optional): A maximum of 20 kg pieces or cuts fit on a total of two shelves. When dry aging meat on the shelves, ensure that the fat is well covered and, if possible, mature on the bone.

5. Ideal aging times are 21-28 days, but an aging time of over 4 weeks is also possible. The taste of the meat then becomes even more intense.

Tip: It is essential to use the functional scope of the integrated SmartAging® technology here in order to make the correct fully automatic setting. Details on that from page 12.

The Dry Aging Bible

Further tips on other foods such as sausage, ham, fish, cheese, vegetables and much more can be found in the book **The Dry Aging Bible** - the ultimate standard work for operating this cabinet.



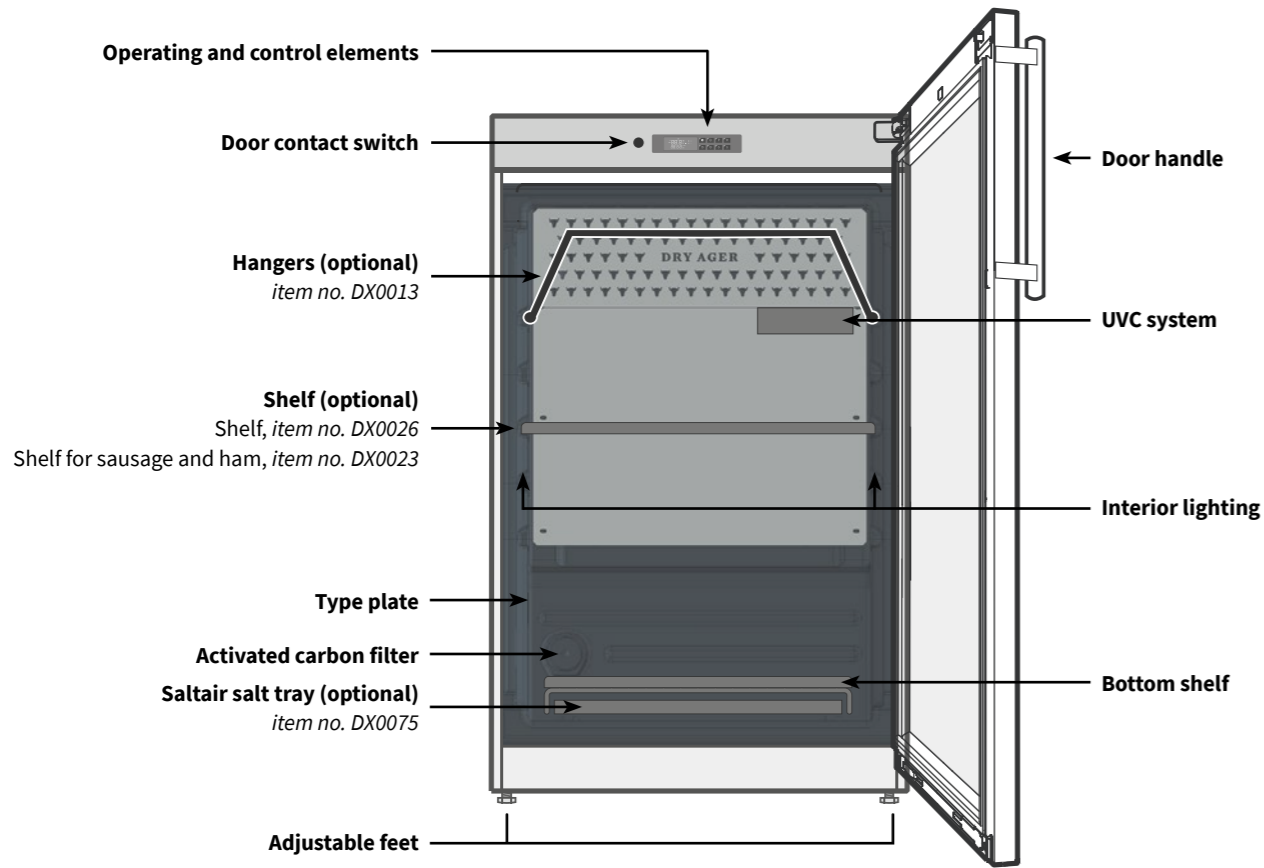

Integrated systems

SmartAging®

Opens up a vast spectrum of dry aging options thanks to innovative program control. Beef, pork, game, poultry, ham, sausage, fish, cheese, wine, herbs, pasta, or fruit. The possibilities are almost endless.

DX TasteReg®

Determine the taste of the fully aged product and choose from three possible intensities (basic/intense/intense+) *.

*not possible for all foods.

Automatic defrost, automatic evaporation of condensation water, visual and acoustic alarm, lockable door, changeable door hinge, integration installation possible, magnetic door seal.

Humicontrol®

Electronic humidity adjustment from 40 to 90% (no water connection required).

DX AirReg®

Optimum air flow, fresh air activated carbon filter and UVC sterilization

DX Led interior lighting

The light spectrum does not contain any ultraviolet radiation. Minimum heat generation, no selective heating of the meat.

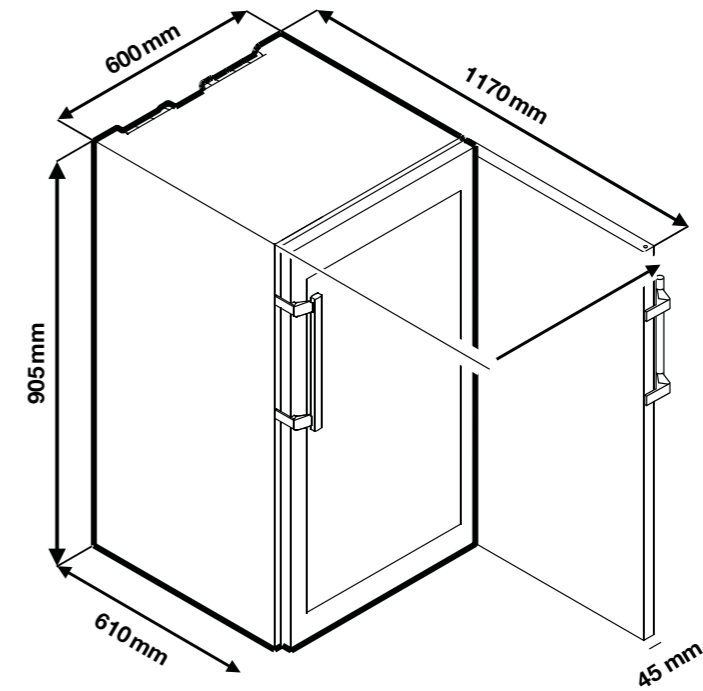

Installation drawings

Single unit

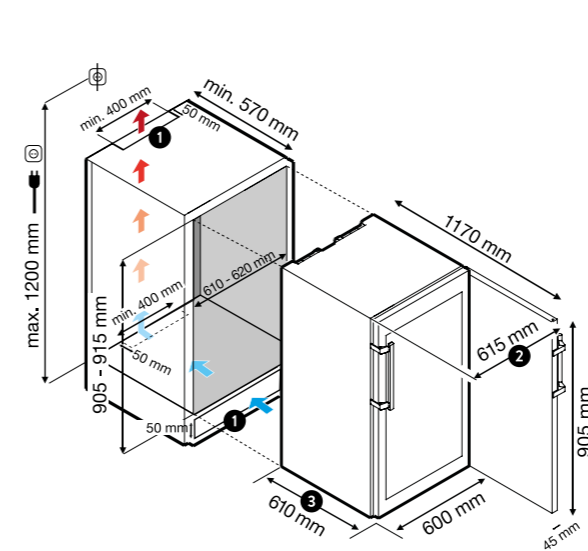

- ❶ Ventilation shafts absolutely necessary. Also possible on the side or on the back. **Minimum size: 200 cm².**
- ❷ Overall dimension with door open: **615 mm.**

Units side by side

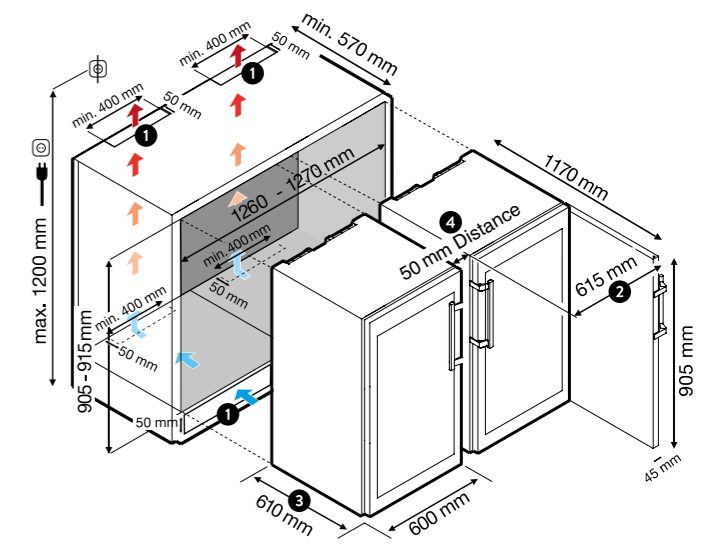

- ❸ Overall dimensions body + door (protruding): **610 mm.**
- ❹ Gap covering of the distance by means of precisely fitting stainless steel trim, available in accessories (item no. DX0031).

Setting up the unit

- Do not set up the unit in an area of direct sunlight, next to a stove, heater or similar.
- The floor at the set-up location should be horizontal and even. Compensate for unevenness using the adjustable feet.

Do not cover ventilation openings or ventilation grilles.

- According to the EN 378 standard, the installation room of the unit must have a volume of 1 m³ per 8 g of refrigerant charge R600a, so that in the event of a leakage of the refrigerant circuit, no ignitable gas-air mixture can develop in the installation room of the unit. The refrigerant quantity is indicated on the type plate inside the unit (page 14).

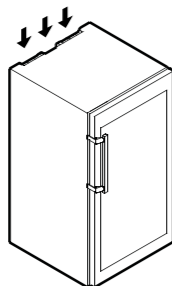

- Always install the unit directly against the wall or install it professionally.

- Remove the orange transport lock.

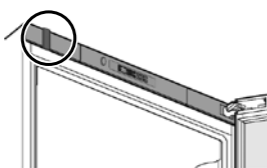

- Install door handle

- Screw the door handle tight.
- Push on the pressure plates until they engage.

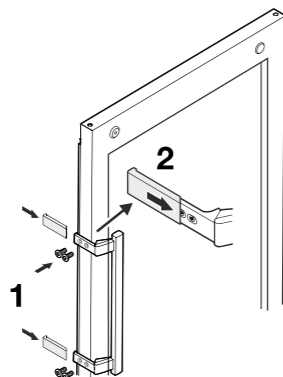

- The floor on which the unit is placed should be horizontal and level. Compensate for uneven floors with the adjustable feet.

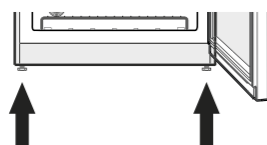

Preparing the unit

1. Clean the unit and accessories

See section **Cleaning**, page 13.

2. Insert the hangers

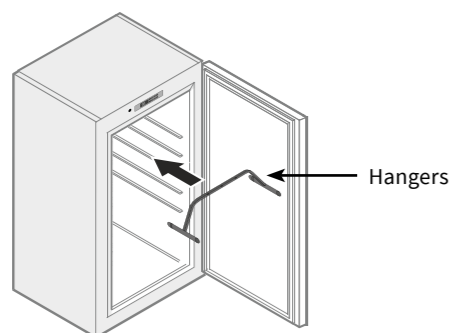

3. Insert grid- and bottom shelf

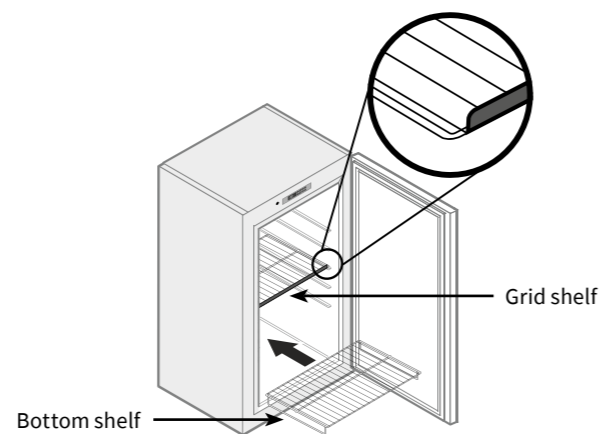

Loading the unit with food

Important note: In order to obtain an optimum end product, it is necessary not to overload the unit and to ensure sufficient space between the products. For example, for sausage production in the DX 500 Premium S, the optimum quantity for loading is 4 kg.

1. Food selection

IMPORTANT

Only use food with a maintained cold chain, that has been handled under perfectly hygienic conditions.

Notes for suitable meat:

- If possible, use fresh meat on the bone no later than 5 days after slaughter or max. 2 weeks vacuum matured meat (remove foil for dry aging).
- Use half saddle or individual cuts (at least 2 kg).
- Use meat with a sufficiently thick protective layer of fat to minimize weight loss during dry aging.
- Recommendation for Dry Aged beef: half saddle from a heifer with good fat layer and marbling.

3. Loading the unit

IMPORTANT

Defrost frozen goods before placing them in the unit.

Wear clean protective clothing (gloves etc) (when handling food).

For optimum Dry Aging air circulation around the food is required: avoid mutual contact of food and its contact with the inner container.

- The humidity control only works properly when the unit is loaded with food.

Option 1: Store food hanging

Example meat



Option 2: Store food horizontally

Example meat

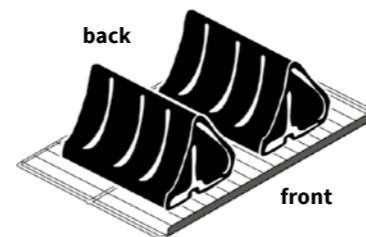
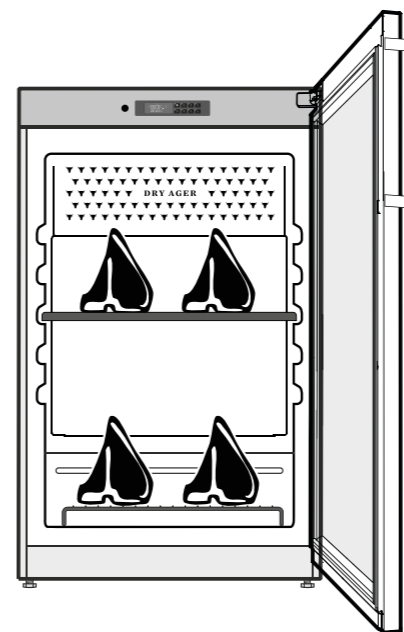

4. Considering maturing time

Many SmartAging® programs specify a aging period. For other programs as well as in Standard Mode, the following times can be considered as a rough guide:

Fresh beef	~ 21-28 days
Fresh pork	~ 14-21 days
Vacuum packed meat	up to 14-18 days
Remove foil before Dry Aging	

During operation

IMPORTANT

It must be ensured that the power supply is not interrupted for long periods of time, in order to maintain the desired microclimate in the unit.

In the event of a power failure that occurs during an aging program, the program progress of the selected program remains saved.

Clean the unit regularly (see section **Cleaning**, page 13).

Check the food regularly. If mold is present, an unusual odor (e.g. pungent, putrid) or any other possible contamination is detected, dispose of the food in accordance with local rules and regulations. Clean the unit thoroughly, according to the section **Cleaning** (page 13).

Switching off the unit

After completion of the aging process, before cleaning the unit or for other reasons, the unit can be switched off as follows:

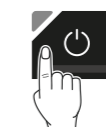

Press and hold button  until "oFF" is displayed and led 4 lights up. The unit is now in standby mode with the compressor switched off.

If the unit is not to be used for a longer period of time, switch it off and disconnect the power plug or trigger the fuse or unscrew it. Clean the unit and leave the door open to avoid odors building up.

Operating and control elements

Overview of controllers



Control buttons

Program selection:
 · Standard mode: "Std"
 · SmartAging® Program: "PG" + program number

· Display remaining time SmartAging program

· Increase the displayed value
 · On / Off button UVC sterilization
 · In Standard mode "dry" for Dry Aging or "SAL" for salami production.

· Decrease the displayed value.

· Viewing/changing the temperature setpoint in **Standard mode**.

· Display/change the humidity setpoint in **Standard mode**.
 · Select or confirm a parameter in the configuration menu of the controller.

· On / Off button interior lighting

· Switch unit On / Off

Control buttons combinations

+ · Locking and unlocking the keypad

+ · Call up the configuration menu of the controller to reset the UVC sterilization after a replacement.

Symbols and characters

Temperature display

Standard mode:
Humidity display

SmartAging® mode:
"PG" + program number

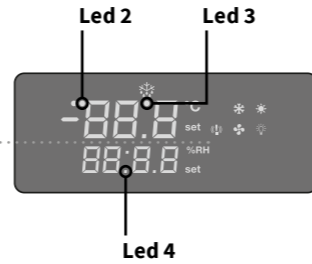

Led / Symbol	Mode	Function
Led 4	On	Unit in stand-by, decimal point
°C	On	°C temperature unit
	On	Cooling
	Flashes	Switch-on delay cooling
Led 3	On	Defrost active
	On	Heating
set	Flashes	Temperature set point / relative humidity set point
	On	An Alarm situation exists
	On	Ventilation active
%RH	On	Relative humidity % unit
Led 2	On	UVC sterilization active
	On	Interior lighting is permanently switched on
	Flashes	Interior lighting is only active due to door opening

Starting operation

1. Power supply

Carefully read the section **Electrical connection** (page 4) before connecting the unit to the power supply socket.

2. Turning on the unit

press until the controller display switches on.

3. Switching the interior lighting on/off (optional)

Press once to switch the interior lighting on permanently. The symbol is shown permanently in the display. Repeat the procedure to turn off the light. Symbol flashes.

Note: When the door is open, the interior lighting is always on automatically.

Interior lighting

The inside of the device is illuminated by an LED light strip at the top of the ceiling and on both sides of the inner container.

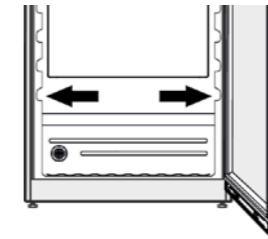

The light intensity of the LED lighting corresponds to laser class RG 2.

IMPORTANT

The light covers may only be removed by customer service.

WARNING

When the cover is removed, do not look directly into the light source with optical lenses from a close range. This can result in damage of the eyes.

4. Switching on the UVC sterilization

Press and hold button for min. 5 s until LED 2 lights up in the display. Repeat the procedure to switch off the UVC sterilization again.

IMPORTANT

During dry aging, UVC sterilization must be switched on.

The DRY AGER® Premium S series cabinet can be operated in two different modes:

Standard mode and SmartAging® mode.

5. Standard mode

Meat aging/ham and sausage aging

The display shows the temperature and humidity levels. In contrast to the SmartAging® programs, setpoints for temperature and humidity can be manually adjusted between 0 - +30°C and 40 to 90 % rH. The factory setting at start-up is 1.5°C and 82 % humidity. This setting is ideal for dry aging beef or pork.

5.1. Activate standard mode

If the display shows temperature and humidity, the standard module is already active. If a SmartAging® program is activated (display "PG" + program number), you can switch to the standard module as follows

1. Press button .
2. Use the arrow button to decrease the program number until "Std" is displayed. Navigate faster by pressing and holding .
3. After a few seconds the standard module starts automatically. The current temperature and humidity are displayed.

5.2. Selection Dry Aging or ham and sausage production

Due to the different requirements for drying and dehumidification during the aging of ham and sausage products compared to Dry Aging, two subordinate modes are distinguished in the Standard mode:

- "dry": use for Dry Aging
- "SAL": use for the production of ham and sausage products

The factory setting is "dry". To switch between the subordinate modes, proceed as follows:

1. Press briefly. The display shows "SAL" or "dry".
2. Press . "SAL" or "dry" flashes.
3. Use the arrow button and to select "dry" or "SAL".
4. Confirm by pressing .
5. After a short time, the display changes to the standard display.

5.3. Setting the temperature



1. Press and hold button for about 5 s until the temperature setpoint is displayed and flashes.
2. Use the arrow buttons and to change the set value.



3. Press button to confirm the set value. The temperature display now shows the actual value.

5.4. Setting the humidity



1. Press and hold button for approx. 5 s until the humidity setpoint is displayed and flashes.
2. Use the arrow buttons and to change the set value.



3. Press button to confirm the set value. The temperature display now shows the actual value.

6. SmartAging® mode

The SmartAging® program (“PG” + program number) and the temperature are shown in the display.

6.1. Select SmartAging® program

Select the appropriate program with the help of chapter (**SmartAging® Program selection**, page 15-18).

Tip: In addition to programs for Dry Aging and the production of sausage products, there are also a variety of special programs, for example, for pre-cleaning the unit, presenting fresh cuts or aging meat from a vacuum bag.

6.2. Start SmartAging®



1. Press the SmartAging® button. LED 2 and LED 3 flash.
2. Use the arrow buttons and to select the desired program. The program starts automatically after a few seconds.
3. The display shows the current temperature and the set SmartAging® program (“PG” + program number).

Note: Displaying the humidity value is not possible during the SmartAging® process.



4. While the program is running, the remaining time can be read with button . The displayed value times 10 is the remaining time in hours. For programs without a runtime, “0.1” is shown in the display.

If an already active program is interrupted by a program change, a completely new program with its own remaining time begins. The previously activated one is irrevocably discarded.

6.3. Finish SmartAging®

After automatic completion of a program with program runtime, the product can be removed or further aged to the desired degree of aging or hardness (e.g. in raw sausage production).



To end a program prematurely, activate the Standard mode (see 5.1 on page 11). The device now regulates again according to the preset setpoints.



The book **The Dry Aging Bible** is perfectly suited to this topic - it covers **SmartAging®** and the huge variety of programs in detail, and the possible range of uses of the unit are much more extensive with the help of this book.

Lock and unlock the keypad (optional)

The buttons of the controller can be locked or unlocked as follows:



Lock

Press and hold buttons and together for about 3 s. “Pof” appears in the display.



Unlock

Press and hold buttons and together for about 3 s. “Pon” appears in the display.

Locking and unlocking the door (optional)

The lock in the door is equipped with a security mechanism.

Locking the unit

- Press the key in direction 1.
- Turn the key by 90°.

To unlock the unit, the same process must be repeated.

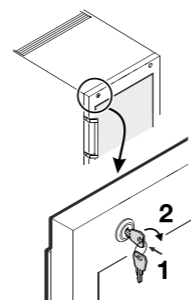

WARNING!

A locked appliance door can lead to children getting trapped and suffocating. Keep the key in a safe place out of the reach of children and away from the unit.

Cleaning



WARNING!

Always shut down the unit before cleaning. Pull out the power supply plug or trigger or unscrew the upstream fuse.

Do not use steam cleaning equipment! Danger of damage and injury.

IMPORTANT

Do not use scouring pads. Do not use any abrasive cleaning agents that contain acidic or chemical solvents. First test the cleaner on a small area in an area that is not clearly visible before cleaning the entire unit.

Do not wipe stainless steel surfaces with dirty or salt-contaminated wiping cloths, as this may result in unsightly rust stains.

Make sure that no cleaning agent or cleaning water penetrates the electrical parts and the ventilation grilles (in the area of the bull heads and UVC sterilization). Do not use a sponge or cloth that is too wet.

The type plate on the inside of the unit must not be damaged or removed. It is important for customer service and any warranty claims.

Frequency of the cleaning process

Regularly clean the device and the accessories used by following the **cleaning steps 1.-5.** below

1. Preparation

- Wear clean protective gloves.
- Remove all food from inside the unit and temporarily store in a refrigerated area.
- Switch off the unit. Then pull out the power supply plug or trigger or unscrew the upstream fuse.
- Remove the used accessories such as shelves, hangers, salt tray from the unit.

2. Cleaning the accessories

- Clean the hanger, the shelves and the salt tray with water and a suitable cleaning agent, such as DRY AGER® Special Cleaner.
- Clean other accessories according to the specified cleaning instructions.

3. Cleaning the interior

- Use a damp (lukewarm water + suitable agent such as DRY AGER® Special Cleaner) soft cloth or sponge to clean the inside of the unit.
- Thoroughly dry all parts with a soft cloth.
- Repeat the cleaning procedure if necessary.

4. Starting the cleaning program

- After each completed aging process, in addition to steps 1 to 3 above, the pre-cleaning program (P16) can also be activated. Duration: 2 hours.

5. Cleaning the outside

- Clean the door surface and the outer walls with a clean, soft cloth. If necessary, a high-quality stainless steel and glass cleaner can be used to clean the corresponding surfaces.

Troubleshooting

Malfunctions

The following malfunctions can be remedied by checking the possible causes yourself.

• The unit does not work. Check if

- the unit is switched on,
- the power plug is correctly plugged into the socket,
- the fuse of the socket is ok.

• The noises are too loud. Check if

- the unit stands firmly on the floor,
- adjacent furniture or objects are vibrating as a result of the cooling unit running. Please note that flow noise in the refrigeration circuit cannot be avoided.

• The temperature is not sufficiently low. Check

- the setting according to section **Setting the temperature** (page 12). Has the correct value been set?
- whether a independently inserted thermometer shows the correct value.
- whether the ventilation is OK.
- whether the installation location is too close to a heat source.

• The condensation water freezes or does not run off in the condensation channel

- clean the drain opening with a suitable object

If none of the above causes exist and the fault cannot be rectified yourself, please contact customer service (see **Customer service**, page 14).

Alarm messages

The alarm messages in the table below are shown on the controller display. These are accompanied by an audible alarm that can be acknowledged and turned off by pressing any button on the controller.

Reporting	Cause	Outputs
P1	Room sensor error	Cooling and heating OFF
P2	Evaporator sensor fault	Defrosting after time. The display alternately shows the alarm message and the actual temperature value.
P3	Humidity sensor error	Humidity control OFF
HA	High temperature alarm	Regulation unaffected
LA	Low temperature alarm	Regulation unaffected
HHA	Humidity HIGH alarm	Regulation unaffected
LHA	Humidity LOW alarm	Regulation unaffected

» Measure

Contact customer service (see **Customer service**, page 14).

Reporting	Cause	Outputs
dA	Door alarm: Door open for a long time	Regulation unaffected

» Measure

The message disappears as soon as the door is closed.

Reporting	Cause	Outputs
UCC	UVC lamp service life reached	Regulation unaffected

» Measure

see section **UVC and activated carbon filter** (page 14).

Maintenance

UVC and activated carbon filter

UV lamp

Type: HNS 5W 2G7 DX, power: 5W, voltage: 24V
radiant power > 0.16 W/m² @ 1m

The UVC lamp and the activated carbon filter must be replaced annually or as soon as the unit shows the warning message “UCC” on the display.

Be sure to follow these maintenance guidelines. If the strength of the UVC light is insufficient, it means that the unit is not working properly.

» Measure

Only order the original DRY AGER® UVC-replacement bulb (*item DX0101*) and the active carbon filter (*item no. DX0110*) and change both parts according to the information on the instructions supplied.

Customer service

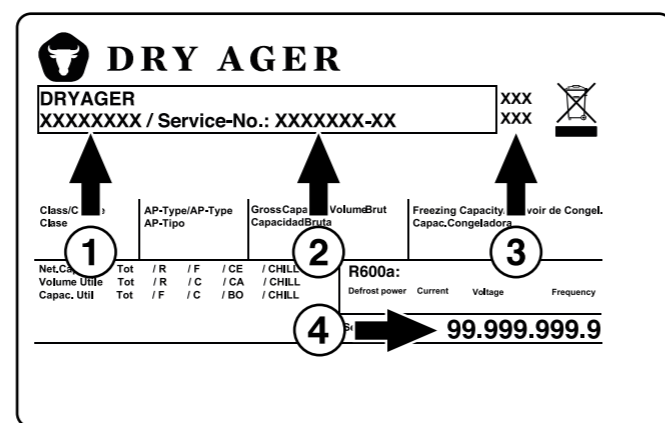

When contacting customer service, provide the type designation **1**, the service number **2**, the service index **3** and the serial number **4** on the type plate.

The position of the type plate can be seen in the chapter **Unit description** (page 6).

Information about the unit

Enter the following information during the installation of the unit:

1 Type designation: _____

2 Service number : _____

3 Service index : _____

4 Series number : _____

Purchase date: _____

Dealer: _____

Disclaimer

The manufacturer assumes no liability for damage to the refrigerated goods, even if the unit is defective within the warranty period. The manufacturer also excludes liability for personal injury caused by improperly stored goods that are subsequently placed on the market.

SmartAging® Program selection

The following questions must be answered in order to select the appropriate program in the program guide on pages 16-18. Special programs are excluded.

1. Which product should be aged?

- Meat
- Fish
- Sausage
- Wine
- Ham
- Cheese
- Poultry



Questions when making sausage or ham? **The Dry Aging Bible** includes detailed instructions and workshops on how to make sausages and hams, for example, or how to prepare fish before it goes into the unit.

2. Questions about meat aging

2.1. Which part should be aged and with or without bones?

2.2. What marbling grade is there?

Determine the marbling grade using the graphics shown.

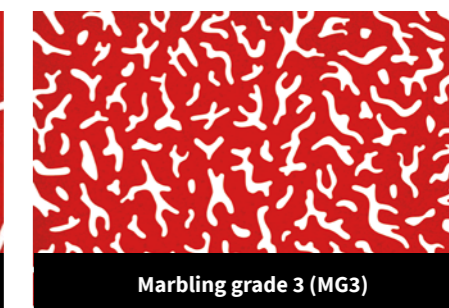
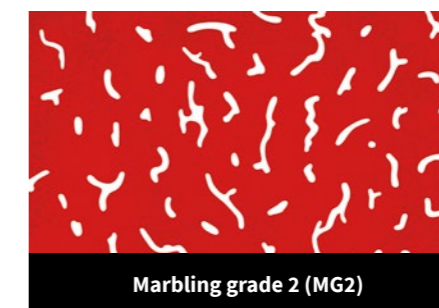
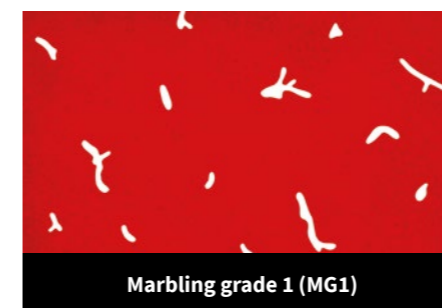

3. How intense should the taste experience be?

Thanks to the **DX TasteReg®** select the desired flavor intensity using the following table.

Product	Intensity	Taste
Beef	Basic	Fresh, meaty, slightly nutty, sweet
	Intense	Nut butter, marzipan, graceful, harmonious, matured, well-rounded
	Intense +	Racy, rooty, blue mold, aromatic, creamy, truffle notes, musky, intense
Pork	Basic	Fresh, meaty, voluminous
	Intense	Well-balanced, harmonious, nutty, supple
	Intense +	Noble mold, velvety, structured, matured, full-bodied
Game	Basic	Fine, melting, characteristic, earthy, mossy
	Intense	Chestnut, forest floor, aromatic, almond, autumn
Lamb/ Kid Goat	Basic	Aromatic, smooth, Mediterranean, elegantly structured
	Intense	Characteristic, bitter, terse, herbal, Mediterranean
Poultry	Basic	Summery, honey, velvety, buttery, floral
Fish	Basic	Well-textured, authentic, well-rounded, pronounced, sophisticated

4. Select the appropriate SmartAging® program

Using the aging table on pages 16-18, select the appropriate program and start it on the device (see **6.2. Start SmartAging®**, page 12).

Dry Aging Compass Beef				
Location	Marbling Classes*	Taste Intensity**		
		basic	intense	intense +
Bone-in				
Whole Back with or without fillet	1	P1 (21 days)	P3 (42 days)	Not possible
	2	P1 (21 days)	P3 (42 days)	P4 (42 days)
	3	P1 (21 days)	P4 (42 days)	P12 (56 days)
Prime Rib	1	P1 (21 days)	P3 (42 days)	Not possible
	2	P1 (21 days)	P3 (42 days)	P4 (42 days)
	3	P1 (21 days)	P4 (42 days)	P12 (56 days)
Rib	1	P1 (21 days)	P3 (42 days)	Not possible
	2	P1 (21 days)	P3 (42 days)	P4 (42 days)
	3	P1 (21 days)	P4 (42 days)	P12 (56 days)
Sirloin	1	P1 (21 days)	P3 (42 days)	Not possible
	2	P1 (21 days)	P3 (42 days)	P4 (42 days)
	3	P1 (21 days)	P4 (42 days)	P12 (56 days)
Chuck Eye Roll	1	P1 (21 days)	P9 (28 days)	Not possible
	2	P1 (21 days)	P9 (28 days)	P5 (28 days)
	3	P1 (21 days)	P5 (28 days)	P3 (42 days)
Leg	1	P1 (21 days)	P9 (28 days)	Not possible
	2-3	P1 (21 days)	P9 (28 days)	P5 (28 days)
Shank	1	P8 (14 days)	P1 (21 days)	Not possible
	2-3	P6 (7 days)	P1 (21 days)	P2 (21 days)
Short Ribs	1	P6 (7 days)	P1 (21 days)	Not possible
	2-3	P6 (7 days)	P1 (21 days)	P2 (21 days)
Deboned				
Tenderloin	1	P6 (7 days)	P8 (14 days)	Not possible
	2	P6 (7 days)	P8 (14 days)	P9 (28 days)
	3	P6 (7 days)	P8 (14 days)	P5 (28 days)
Rib	1	P1 (21 days)	P2 (21 days)	Not possible
	2-3	P1 (21 days)	P9 (28 days)	P5 (28 days)
Sirloin	1	P8 (14 days)	P1 (21 days)	Not possible
	2-3	P1 (21 days)	P2 (21 days)	P5 (28 days)
Rump Cap	1	P8 (14 days)	P1 (21 days)	Not possible
	2-3	P1 (21 days)	P9 (28 days)	P5 (28 days)
Topside	1	P8 (14 days)	P1 (21 days)	Not possible
	2-3	P9 (28 days)	P3 (42 days)	P4 (42 days)
Top Blade/ Flatiron Steak	1	P8 (14 days)	P1 (21 days)	Not possible
	2-3	P1 (21 days)	P9 (28 days)	P5 (28 days)
Shoulder Clod	1	P8 (14 days)	P1 (21 days)	Not possible
	2-3	P9 (28 days)	P3 (42 days)	P4 (42 days)
Tri Tip	1	P8 (14 days)	P1 (21 days)	Not possible
	2-3	P9 (28 days)	P3 (42 days)	P4 (42 days)
Tongue	-	P1 (21 days)	P3 (42 days)	Not possible
Heart	-	P8 (14 days)	P1 (21 days)	Not possible

Dry aging compass beef - with and without bone; *Marbling classes see page 15; **Taste intensity see page 15

Dry Aging Compass Pork				
Location	Marbling Classes*	Taste Intensity**		
		basic	intense	intense +
Bone-in				
Whole Back with or without fillet	1	P6 (7 days)	P8 (14 days)	Not possible
	2	P8 (14 days)	P1 (21 days)	P9 (28 days)
	3	P8 (14 days)	P1 (21 days)	P5 (28 days)
Leg	1	P6 (7 days)	P8 (14 days)	Not possible
	2	P7 (7 days)	P1 (21 days)	Not possible
	3	P7 (7 days)	P1 (21 days)	P9 (28 days)
Head	1-3	P8 (14 days)	P1 (21 days)	P2 (21 days)
Deboned				
Tenderloin	1-2	P6 (7 days)	P7 (7 days)	Not possible
	3	P6 (7 days)	P8 (14 days)	Not possible

Dry aging compass pork - with and without bone; *Marbling classes see page 15; **Taste intensity see page 15

Dry Aging Compass Lamb, Kid Goat, and Game				
Location	Marbling Classes*	Taste Intensity**		
		basic	intense	intense +
Bone-in				
Whole Lamb / Kid Goat	1	P10 (14 days)	P11 (21 days)	Not possible
Saddle of Lamb/ Kid Goat	1	P6 (7 days)	P11 (21 days)	Not possible
Leg of Lamb / Kid Goat	1	P6 (7 days)	P11 (21 days)	Not possible
Saddle of Boar	1	P6 (7 days)	P11 (21 days)	Not possible
	2	P10 (14 days)	P11 (21 days)	Not possible
Leg of Boar	1	P6 (7 days)	P10 (14 days)	Not possible
	2	P10 (14 days)	P11 (21 days)	Not possible
Chuck of Deer	-	P10 (14 days)	P11 (21 days)	Not possible
Saddle of Deer	-	P6 (7 days)	P11 (21 days)	Not possible
Leg of Deer	-	P6 (7 days)	P11 (21 days)	Not possible

Dry aging compass pork - with and without bone; *Marbling classes see page 15; **Taste intensity see page 15

Dry Aging Compass Poultry				
Location	Marbling Classes*	Taste Intensity**		
		basic	intense	intense +
Whole Poultry				
Duck	-	P13 (5 days)	Not possible	Not possible
Chicken	-	P13 (5 days)	Not possible	Not possible
Pheasant	-	P13 (5 days)	Not possible	Not possible
Goose	-	P13 (5 days)	Not possible	Not possible
Quail	-	P13 (5 days)	Not possible	Not possible

Dry aging compass poultry - with and without bones; *Marbling classes see page 15; **Taste intensity see page 15

Changing the door hinge

The door hinge should only be changed by trained specialists. Two people are required for the modification.

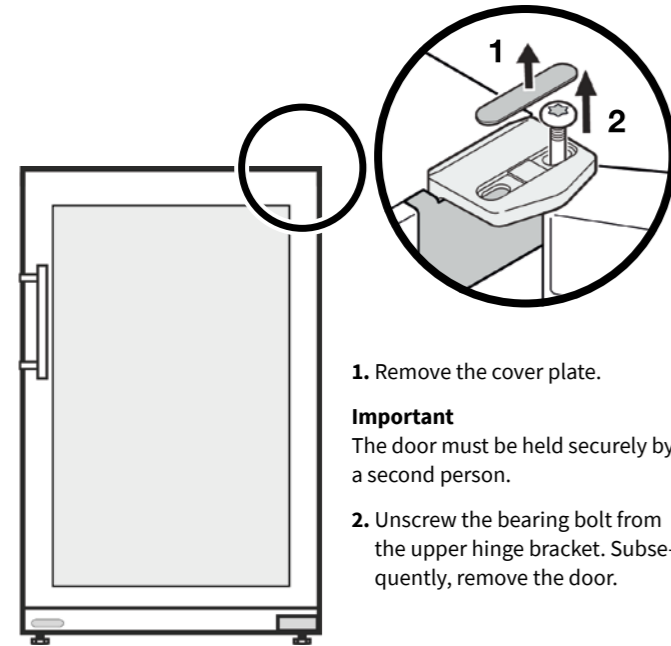

3. Set the clamping plate on the opposite side.

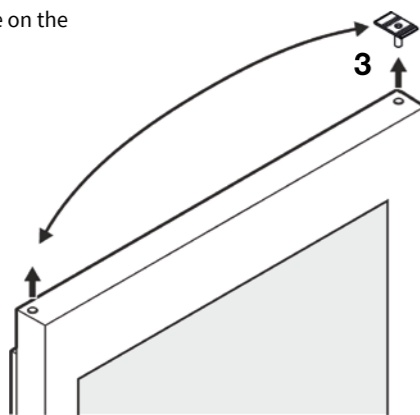

4. Loosen front pressure plates ① and pull back to remove ②.

5. Unscrew the door handle and assemble it again on the opposite side.

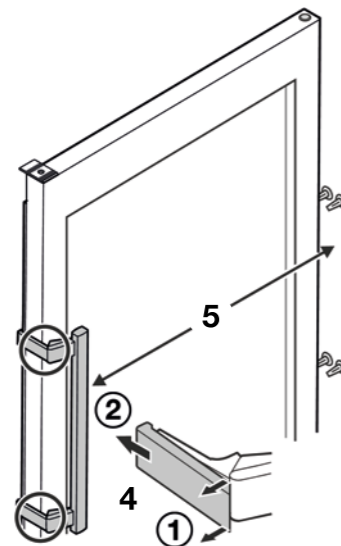

6. Set the hinges and cover plates on the opposite side.

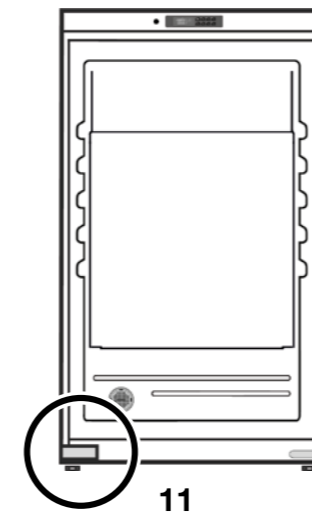
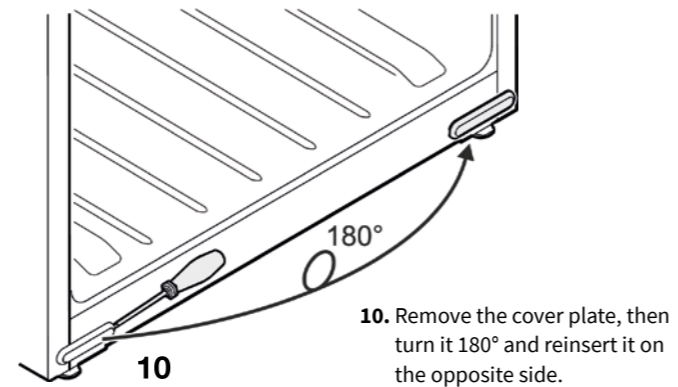
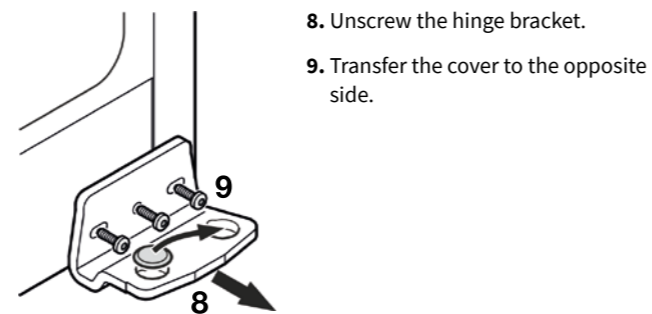
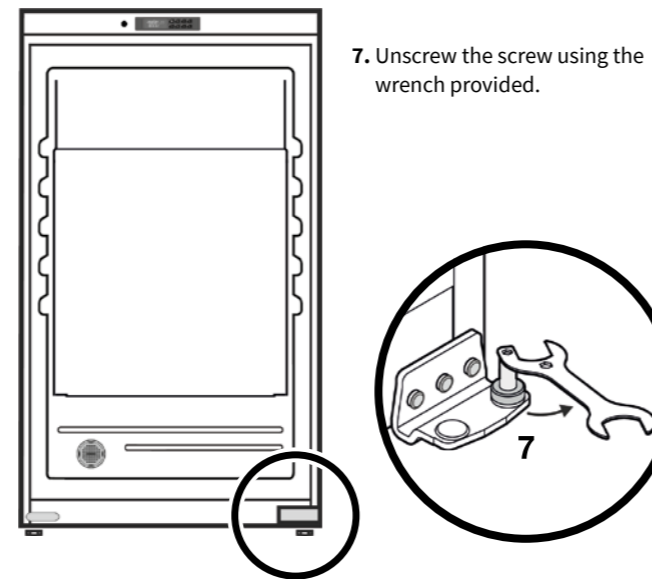
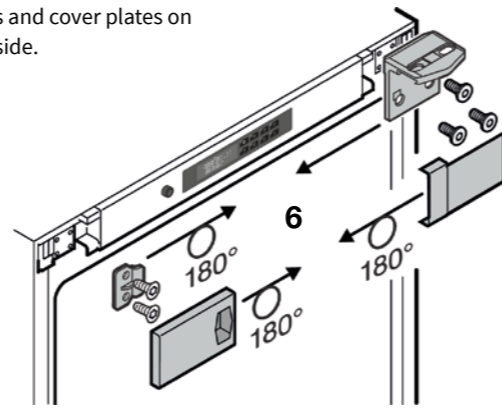

11. Screw on the hinge bracket.

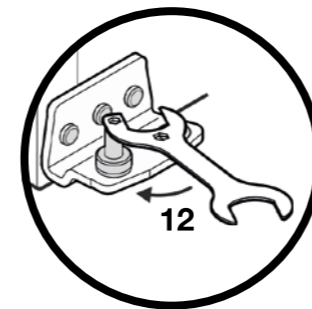
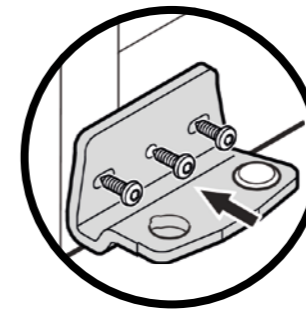

12. Tighten the screw.

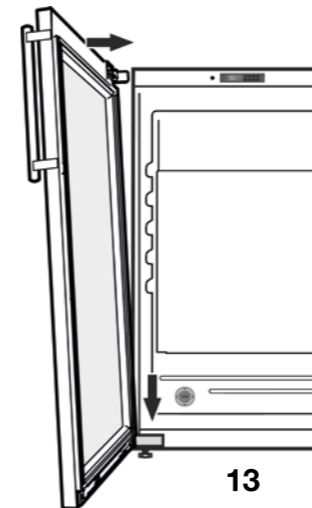

Attention

the door must be held by a second person!

13. Place the door on the latch and guide it to the upper edge of the hinge.

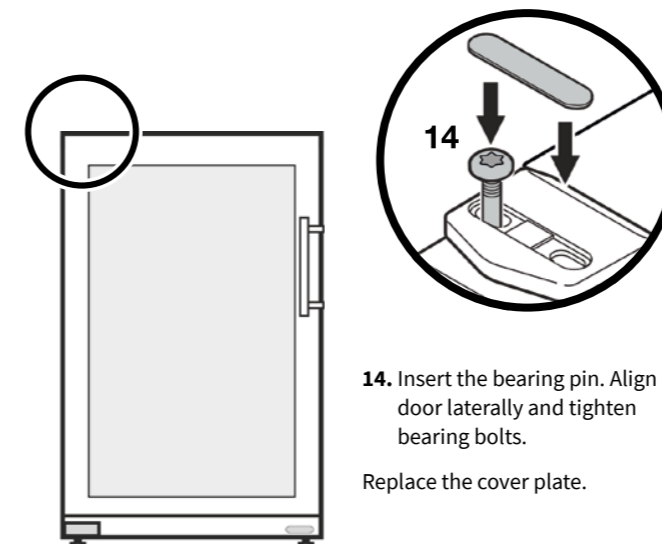

14. Insert the bearing pin. Align door laterally and tighten bearing bolts.

Replace the cover plate.



DRY AGER

BUILT FOR BEEF

Landig + Lava GmbH & Co. KG – DRY AGER® Manufacturer
Mackstrasse 90 – 88348 Bad Saulgau

Phone: +49 7581 90 43 0 - email: info@dry-ager.com

Website: www.dry-ager.com



www.facebook.com/thedryager



twitter.com/Dry_Ager



www.instagram.com/dryager



www.dry-ager.com